

Development and Acceptance Testing of the Dual Wheel Mechanism for the Tunable Filter Imager Cryogenic Instrument on the JWST

Martin Leckie* and Zakir Ahmad

Abstract

The James Webb Space Telescope (JWST) will carry four scientific instruments, one of which is the Tunable Filter Imager (TFI), which is an instrument within the Fine Guidance Sensor. The Dual Wheel (DW) mechanism is being designed, built and tested by COM DEV Ltd. under contract from the Canadian Space Agency. The DW mechanism includes a pupil wheel (PW) holding seven coronagraphic masks and two calibration elements and a filter wheel (FW) holding nine blocking filters.

The DW mechanism must operate at both room temperature and at 35K. Successful operation at 35K comprises positioning each optical element with the required repeatability, for several thousand occasions over the five year mission.

The paper discusses the results of testing geared motors and bearings at the cryogenic temperature. In particular bearing retainer design and PGM-HT material, the effects of temperature gradients across bearings and the problems associated with cooling mechanisms down to cryogenic temperatures. The results of additional bearing tests are described that were employed to investigate an abnormally high initial torque experienced at cryogenic temperatures. The findings of these tests, was that the bearing retainer and the ball/race system could be adversely affected by the large temperature change from room temperature to cryogenic temperature and also the temperature gradient across the bearing. The DW mechanism is now performing successfully at both room temperature and at cryogenic temperature. The life testing of the mechanism is expected to be completed in the first quarter of 2010.

Introduction

The TFI, which includes the DW mechanism, is shown in Figure 1 (labelled "Filter Wheel Assembly"). The TFI has been designed to provide infra-red narrow band imaging in the 1.5 to 5 micrometer wavelength range. In order to make these observations, it has stringent temperature requirements. The TFI temperature is approximately 35K for JWST science observations.

The role of the DW mechanism is to place optical elements into the optical path, in any combination of corona graphic mask and blocking filter. The optical elements must be placed accurately and in a highly repeatable manner.

The paper discusses the following topics. First, the design of the DW is described in some detail so that the function of each component is clarified for the reader. Secondly, the test results of component parts and the DW assembly are described in more detail.

The geared motor test results are described first and the bearing tests second. The bearing tests revealed an abnormally high start up torque, at cryogenic temperatures, which led to an in depth investigation of this issue.

* COM DEV Ltd., Cambridge, Ontario, Canada

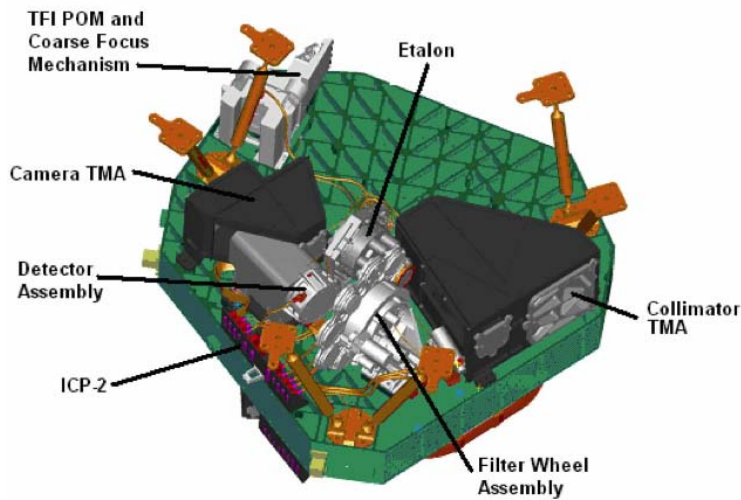

TFI Side

Figure 1. Fine Guidance Sensor – TFI Side

The high initial start up torque at 35K of the bearings was attributed to three causes. The first cause was mitigated by a retainer design change. The second and third causes have been investigated and understood, such that confidence in the flight design is high. The results of the investigation are presented, together with the lessons learned from the problem. Finally, the results of the flight model testing are discussed.

Design Description

A general arrangement of the DW mechanism is shown in Figure 2. The main components are the pupil and filter wheels, bearings, gears, static hub, motor/resolver support plate and the support bracket. The DW mechanism also includes geared stepper motors, resolvers and variable reluctance sensors. A cross section of the DW mechanism is shown in Figure 3. Each wheel (approximately 280-mm diameter) rotates on a duplex pair of angular contact preloaded bearings.

A stepper motor is used to drive each wheel, through a reduction gear train. The stepper motor has been geared down to enable the positional accuracy requirements for each optical element to be met. A resolver provides feedback to confirm that each wheel is in the correct position. Flight software uses the resolver reading to calculate a position adjustment to bring the wheels to the correct position.

All moving parts are lubricated with MoS₂ dry lubricant to be compatible with the cryogenic temperature requirements. The wheels (the bearing housing) and the hub (the bearing shaft) were machined from titanium Ti-6Al-4V. The selection of titanium alloy was dictated by a requirement for low mass and also to closely match the coefficient of thermal expansion (CTE) of the 440C stainless steel bearings.

The bearings were manufactured by ADR of France, with the MoS₂ dry lubricants and the PGM-HT retainer added by ESR Technology in the UK. The bearings are located at the center of gravity of each wheel in order to reduce the bending moments acting on the bearings during launch. The bearing size, ball diameter, and preload are designed to balance the critical requirements – high enough preload to meet the stiffness requirement, but still low enough to allow low running torques and stresses.

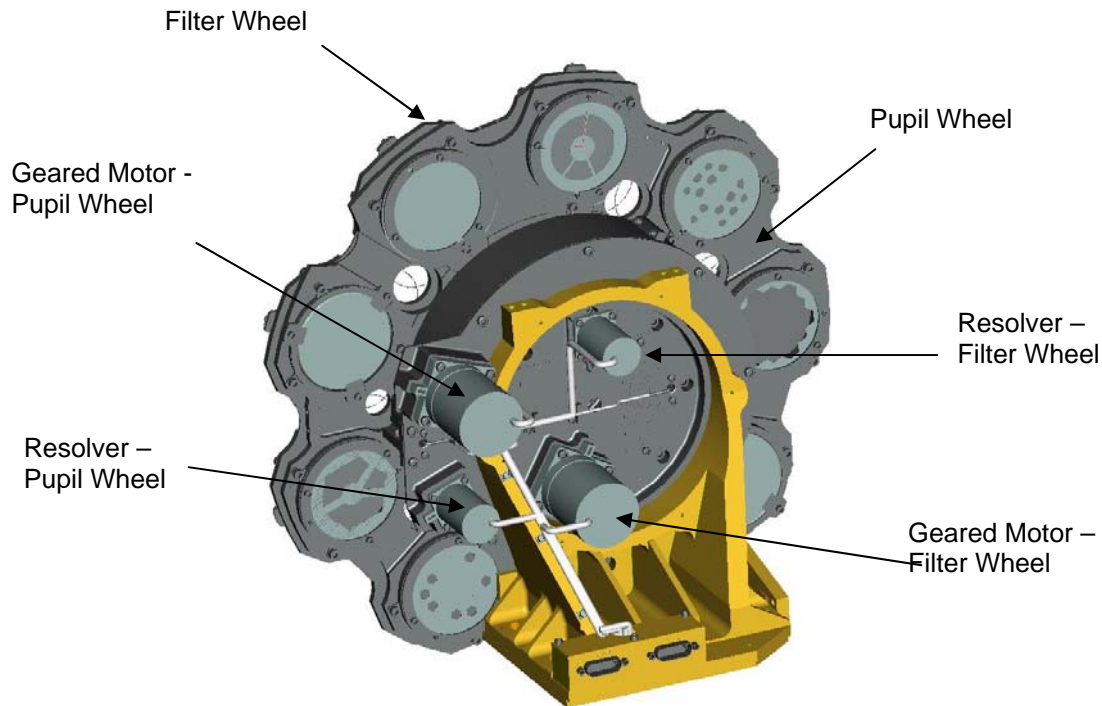

Figure 2. Dual Wheel Mechanism – General Arrangement

Each bearing is secured in place with clamping nuts. Each nut includes a flexure, which is preloaded by the action of torquing the nuts into place. The flexures maintain the preload on the bearings, despite the slight difference in the coefficient of thermal expansion between the 440C bearings and titanium housings. The PW bearing installation is shown in detail in Figure 4. The FW bearing installation is similar.

The bearing “fits” to the wheel and hub are sized so that a line on line to a clearance fit is obtained at the mechanism operating temperature range of 35K. The selection of a small clearance fit at the cryogenic temperature, necessitates that an interference fit between the bearings and shafts exist at room temperature, at the outer diameter. The use of a clearance fit at the cryogenic temperatures is to eliminate bearing race distortion, which could cause variations in bearing preload. The bearing fits were verified using a bread board model (BBM) filter wheel mechanism, tested at 35K. The BBM also served to determine bearing torque at 35 K and to determine a suitable baseline for the motor drive current.

The PW and the FW wheel are each rotated via a pinion and ring gear. The pinion gears are made from stainless steel 13-8 PH and the ring gears are made from stainless steel 17-4 PH. Both gears are lubricated with MoS₂ dry lubricant. The gear tooth size was evaluated using AGMA standards for tooth contact stress and tooth bending stress.

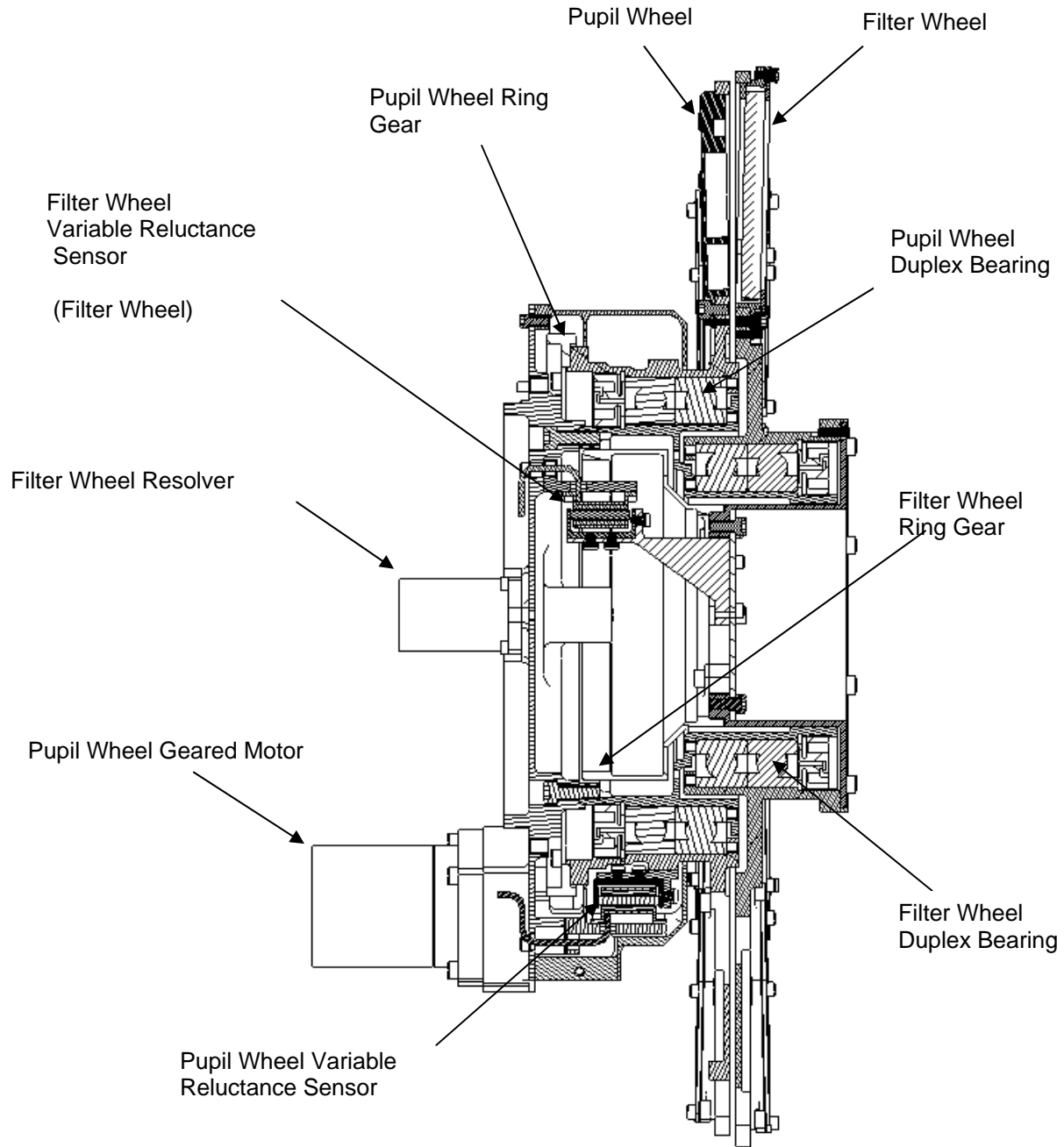

Figure 3. Dual Wheel Mechanism – Cross Section

The gear ratios were selected to give the desired size of granularity of movement of the PW and FW wheel and to reduce same tooth encounters between the pinion gear teeth and the ring gear teeth.

Each wheel is driven by a geared motor. The geared motor drives a pinion gear, which meshes with each ring gear. The geared motor was procured from CDA Intercorp and is comprised of an 8 pole, 3 phase stepper motor, having a 15° step angle and a planetary gear stage having a ratio of 9.6:1. The geared motor bearings and planetary gears were lubricated with Ball Aerospace MoS₂ lubricant.

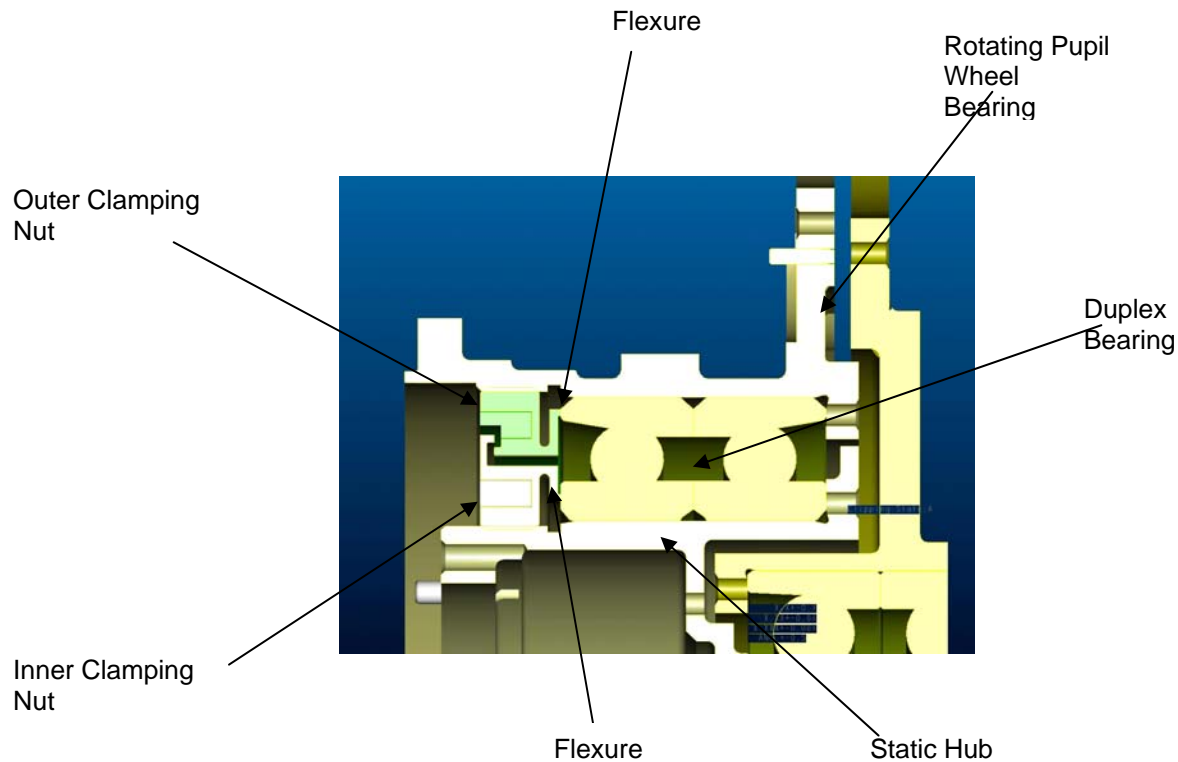

Figure 4. Pupil Wheel Bearing Installation

The geared motors support wheel rotational speeds of 1.5 RPM. The geared motor sizing was based on providing sufficient torque margin when taking into account the resistive torques, due to accelerating the rotational inertia of the wheels and the resistive torque of the bearings. The appropriate factors were applied to the resistive torques, in order to calculate torque margins. The specified output torque of the geared motor was based upon previous measured performance of geared motors completed by CDA Intercorp and the estimate of the resistive torques was based upon measurements of the BBM filter wheel bearing at cryogenic temperatures.

The DW mechanism design has to meet the positioning and repeatability requirement having considered the contributing errors. These errors include the variation in stepper motor step angle, geared motor backlash error, resolver error, ring / pinion gear backlash, tooth pitch variation, thermal distortion and component machining tolerances. Having analyzed the errors, the granularity of wheel motion (and hence gear ratios) were sized to be smaller than the required accuracy.

A resolver position sensor provides feedback to confirm that the wheel is in the proper position. An anti-backlash gear is used on the resolver output pinion to increase the accuracy of this gear train. Since the resolver is geared up by a factor of 9, the resolver turns 9 times for every rotation of the wheel. The resolver provides an absolute read-out, but pending a loss of memory due to a fault condition, the resolver would be unable to determine which 1/9th of a segment the wheel would be in. A reference signal is therefore provided to indicate a home position. The reference signal is provided by a variable reluctance sensor (VR sensor).

Geared Motor Testing – Lessons Learned

The actuation to rotate each wheel is provided by a geared motor. The geared motor is a combination of a three phase stepper motor (step size of 15 deg.) and a single stage planetary gear. The geared motor for the PW is shown in Figure 5.

The geared motor testing was first completed at room temperature. It was important to establish a baseline of the motor performance at room temperature before testing at cryogenic temperatures.

Any issues with the geared motor would have to be found before introducing the motor drive electronics. The motor drive electronics are a COM DEV design. The drive electronics cater to room temperature and cryogenic operation of the motor. This is achieved through a continuous real time measurement of motor winding resistance and a subsequent adjustment of voltage (through time modulation techniques).

The first round of room temperature testing yielded a pull in torque value of 17 N-cm versus a specified requirement of 23 N-cm. This was thought to be a simple shortfall in motor performance and certainly not a design problem. It was decided to proceed to cryogenic temperature testing. The testing at cryogenic temperatures was carried out in a cryogenic chamber together with a feed thru shaft out of the chamber coupled to a torque measurement machine.

The first test at 35K did not result in full rotation of the motor. The motor exhibited some stalling and an investigation was started through the material review board process. Considering the observations, the motor performance appeared normal at room temperature, but the performance at 35K was abnormal. The cause was immediately thought to be a deficiency in the motor and that the cryogenic environment must be causing more friction in the motor bearings and planetary gears.



Figure 5. Geared Motor – Pupil Wheel

The geared motor vendor (CDA Intercorp) was requested to use their own design of drive electronics with the geared motor tested again at cryogenic temperature. The material review board chose the motor “no load response rate” as the most appropriate data to obtain at cryogenic temperature. The “no load response rate” is the maximum speed that the motor can rotate at, in a stable manner, without any load. The “no load response rate” provides a good indication of the health of the geared motor. Higher friction in the geared motor would lead to clear change in the “no load response rate”.

At 35K with the vendor drive electronics, the geared motor was able to rotate at the same “no load response rate” that was obtained at room temperature. This finding proved that the geared motor was not suffering from increased friction at cryogenic temperatures. It was therefore concluded that in some way

the drive electronics were not providing the correct pulses to the motor. The fact that the motor had provided full rotation and a pull in torque value of at least 75% of the specified requirement, at room temperature, seemed to indicate that all was well with the drive electronics.

The first review of the drive electronics test data showed that the current, voltage and power being delivered to the motor at 35K were indeed correct. We expected that these parameters would in some way, be out of specification.

A more detailed and thorough review of the drive electronic motor pulses revealed a problem in the stepping sequence. The stepper motor operates using a six step sequence of closed and open circuits for the three windings. The sequence is provided to the motor by virtue of programming of an FPGA in the drive electronics. It was found that the sequence in the FPGA was actually making the motor step from position 1 to position 3 to position 5 and then to position 1 again. This did cause the motor to rotate, but with diminished torque and half the power. This caused the anomalous behavior at cryogenic temperature and the below specification pull in torque at room temperature. When the sequence was corrected and the motor was tested again at 35K, motor performance was excellent.

Several new technologies had been put into one test, dominated by a new motor design, and its new drive electronics; all operating at the cryogenic temperature environment. This fact made it very difficult to determine the root cause of the issue. The anomalous behavior was incorrectly attributed to the geared motor because the assumption that the drive electronics were correct had been established at room temperature. A month later the problem had been traced back to the stepping sequence in the drive electronics. Also, all of the motor test data gathered at ambient and cryogenic temperature had to be repeated. The lesson learned was that a test should not try to combine too many new technologies in the first test. A check of all items that could affect motor performance should be completed before assigning a cause to a problem.

Thanks go to our vendor, CDA Intercorp, for their timely assistance in trouble shooting this problem. In this case, it was very beneficial to have a "reference" set of drive electronics to expedite testing at the cryogenic temperatures.

Ball Bearing Testing

The PW and the FW wheel bearings are critical items for the dual wheel mechanism. For each mechanism, the torque ratio would in large part be determined by the torque exhibited by these bearings at cryogenic temperatures. An extensive test program was devised to determine bearing performance at cryogenic temperatures.

The design parameters of each bearing are shown in Table 1. A single bearing for the PW and the duplex pair bearing for the PW installed in the PW machining is shown in Figure 6.

It was decided early in the program that the initial bearing tests would be carried out with the bearings already installed in the wheel and hub assembly. It was originally thought to be highly desirable to test the bearings in their actual flight configuration and that "bearing only" tests would be un-necessary. This philosophy would later prove to be overly optimistic.

Table 1: Bearing Design Parameters

BEARING	I.D. (mm)	O.D. (mm)	RACE WIDTH (mm)	BALL DIAMETER (mm)	BALL COMPLEMENT	CONTACT PRESSURE ANGLE	PRELOAD (N)	RETAINER MATERIAL
Filter Wheel	65	90	13	7.94	25	25	712	PGM-HT
Pupil Wheel	100	125	13	7.14	34	25	712	PGM-HT

The cryogenic chamber test set up for the wheel / hub assembly is shown in Figure 7. Note that the cryogenic chamber has a cold plate surface, to which the device under test (DUT) is directly attached.

Each wheel/hub assembly was run-in for 100 revolutions CW and 100 revolutions CCW at room temperature. The torque of the bearings was then measured. Each bearing torque at room temperature was in the range of 8 to 12 N-cm. This was certainly acceptable and proved that the bearings had been successfully installed into the wheels. The next set of torque tests would be carried out at cryogenic temperature.

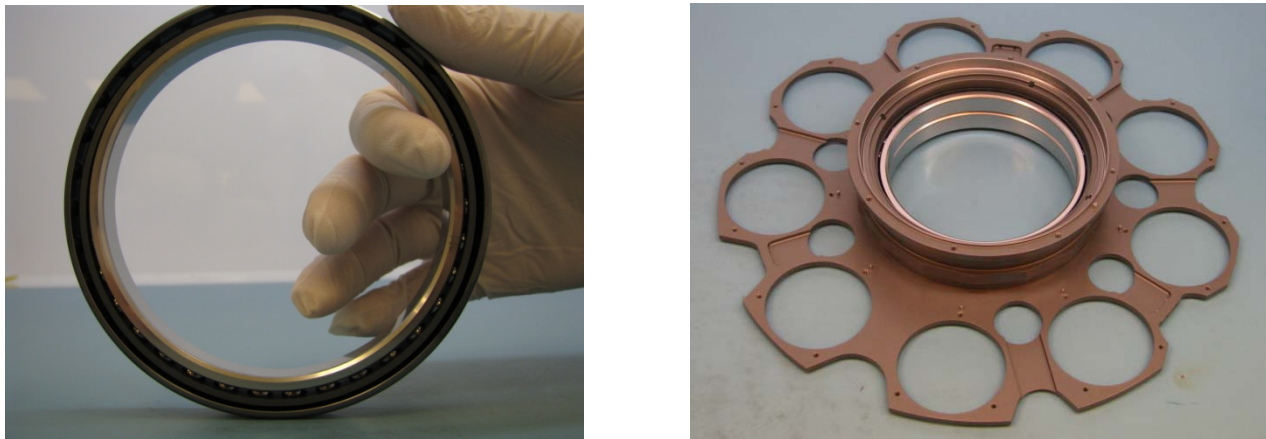

Figure 6. Single Pupil Wheel Bearing & Duplex Pair installed in Pupil Wheel Machining

The wheel/hub assembly was installed in the cryogenic chamber. The chamber was purged with dry N₂ gas for a period of 2 hours (this was the standard purging used for all cryogenic tests) and then a vacuum was drawn in the chamber. The DUT was then cooled down to 32K and a record was maintained of the wheel and hub temperature. It was noted that the wheels cooled at a much slower rate than the hub, leading to a 100K temperature gradient across the bearings.

The PW bearing (cryogenic) torque was measured first. The initial torque measurement was carried out with a hand held torque meter. The initial torque measurement was abnormally high at 202 N-cm. This result was unexpected and indicated that a problem with the bearing was occurring. An investigation of the problem was started and it was decided to continue rotation of the bearing to further characterize the problem. After 4 revolutions, the torque had dropped from 56 to 46 N-cm. After a further 100 revolutions the torque had reduced to 20 N-cm. After a total of 200 revolutions the torque had reduced to 6 N-cm.

The FW bearing (cryogenic) exhibited a similar problem, with an initial torque measurement of 196 N-cm. The behavior when further rotated was similar to the PW bearing, with the torque reducing to an acceptable value of 5 N-cm over the first 100 revolutions.

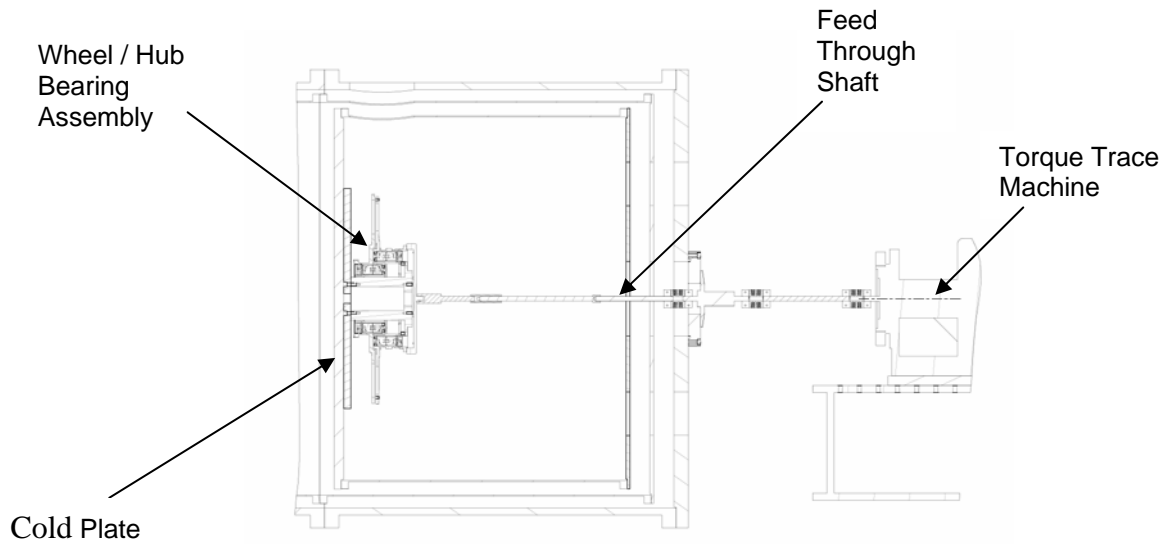

Figure 7. Wheel / Hub Assembly in the Cryogenic Chamber

The bearings were being impeded by something when initially rotated. Over the first four revolutions the torque reduced but was still very high. Eventually an acceptable value of torque (approx. 5 N-cm) was achieved on both bearings after 200 revolutions. The fact that the bearing torque at cryogenic temperature was similar to the ambient torque, after 200 revolutions was encouraging because it implied that the bearings were not permanently distorted by the wheel and hub at 35K. If they were permanently distorted, it did not seem credible that they would ever run well. It was decided to disassemble the wheel/hub assembly, to the extent possible, to make a visual inspection of the bearings. The visual inspection revealed particles of material in the form of flakes and small threads in the vicinity of the retainer and the races. The particle contamination in the bearing is shown in Figure 8.

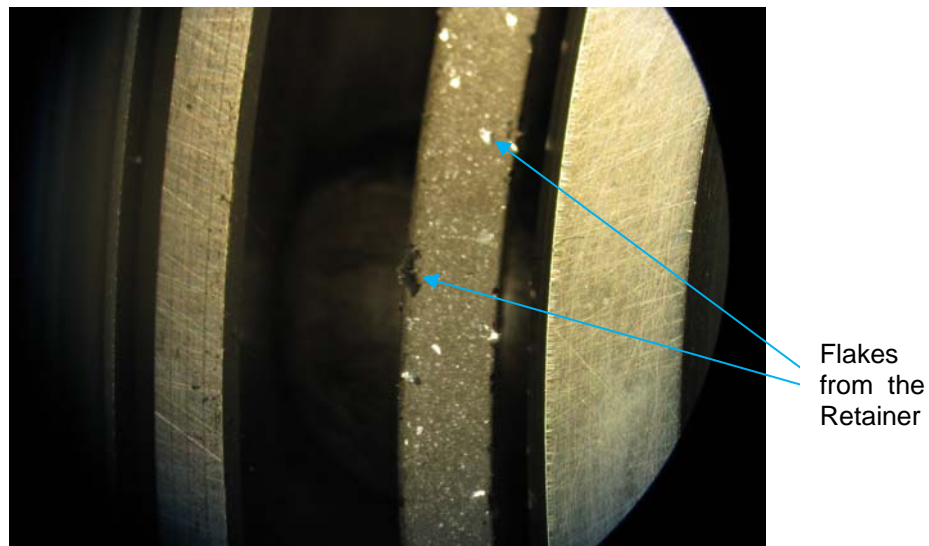

Figure 8. Wheel / Hub Assembly in the Cryogenic Chamber

The particles were identified (by chemical analysis) to be MoS₂ and PGM-HT. Therefore, it was concluded that the retainer was implicated in the problem. The retainer design was reviewed and a dimensional shrinkage analysis of the retainer and race was undertaken.

The retainer design for these bearings had to address two modes of operation. The first, being a floating retainer at room temperature and second, an inner race riding retainer at cryogenic temperature. The extreme temperature change, combined with the large CTE value of PGM-HT, means that the retainer would have only a small clearance from the inner race at cryogenic temperature.

Differential thermal contraction between the cages and the bearing races must be taken into account in the design since operational range is 295K – 35K, hence for this design the validity of CTE data is critical. When the retainer was originally designed, the CTE values used for calculating clearances at 35K was $52 \times 10^{-6} \text{ K}^{-1}$ for PGM-HT and $8 \times 10^{-6} \text{ K}^{-1}$ for 440C [1] over the temperature range of 295K – 35K. A review of more recent test data (provided by ESR Technology) revealed that the CTE of PGM-HT could vary from $80 \times 10^{-6} \text{ K}^{-1}$ at 295K to $60 \times 10^{-6} \text{ K}^{-1}$ at 125 K. No data existed below 125K, so CTE values for the temperature range of 125K to 35K were extrapolated from the most recent data.

The larger values of CTE were used in a dimensional shrinkage analysis of the retainer and the bearing inner race. The results of the analysis showed an interference condition could occur between the retainer and the inner race at approximately 90K for the PW bearing and 60K for the FW bearing.

It was decided to confirm the findings of the analysis by test. The PW bearing was tested again at cryogenic temperature, with torque measurements made at 50, 70, 90 and 100K. The test revealed that below 80K, torque was greater than 50 N-cm. When above 100K, torque was only 10 N-cm. This test confirmed our supposition that an interference was occurring and it was decided to re-make new retainers with a larger inside diameter. The new CTE value was used for the new retainer design. Thanks go to our vendor, ESR Technology for their timely assistance with this issue.

With all bearings having a revised larger retainer installed, the test philosophy of the program was revised. Both the PW bearing and the FW bearing would be tested at the bearing level, at cryogenic temperature. A bearing test fixture was designed by ESR Technology and COM DEV. A novel feature was the addition of a “window” so that a direct view of the retainer could be seen at cryogenic temperature. Temperature sensors were also added to directly monitor inner and outer race temperatures.

The first cryogenic test of a bearing (with the new retainer) gave us a surprise. The bearing still exhibited a high torque when initially rotated at cryogenic temperature (approx. 50 N-cm) but a lower value than that seen before. The bearing recovered quickly to a normal value (10 N-cm) when rotated two revolutions. The good news was that the retainer could be seen to have the design clearance of approximately 0.4 mm from the inner race at cryogenic temperature. The fixture “window” and the clearance are shown in Figure 9.

The post test inspection of the bearing showed no flakes and particles had come off the retainer. The conclusion of the test was that there was still a problem with the bearing, but not necessarily related to the retainer interference issue. A solution to the problem had not yet been found, but the initial torque of 50 N-cm could easily be accommodated by the driving torque available for the geared motor. As a precaution, it was decided to torque test all bearings at 35K. The tests revealed that all bearings had a higher than normal torque when initially rotated at cryogenic temperature. However, bearings having the lowest values of initial torque (≤ 50 N-cm) were selected for flight and the life test program.

The investigation team was re-convened to establish a root cause for the problem. All evidence from the tests to date was reviewed and it was decided to further investigate the effects of the large thermal gradient, which was occurring across the bearing during the cool down. It was already known at this time that the cool down of the DW mechanism over a period of 6 days or less would invite the large thermal gradient across the bearing to occur and therefore may cause the high initial torque at cryogenic temperature to occur in the DW mechanism. A further series of pupil wheel bearing tests were carried out to further characterize the problem and investigate possible mitigation strategies.

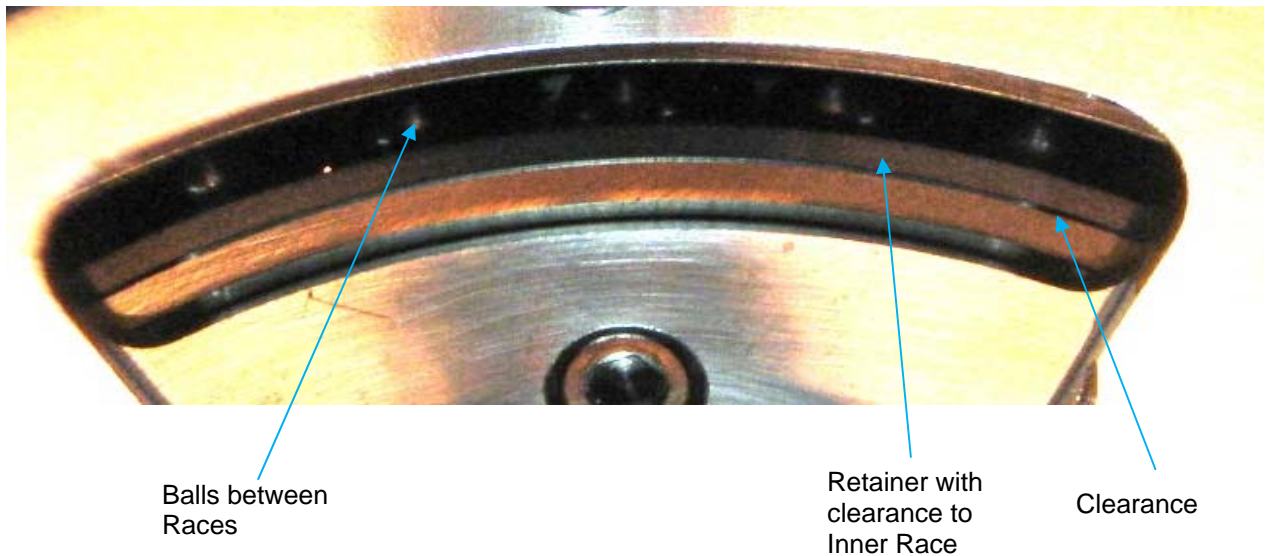

Figure 9. Pupil Wheel Bearing Test at 35K viewed through Test Fixture Window

Bearing Test 1 Objective: To quantify the temperature gradient across the bearing when preload is lost. Pupil wheel bearing was torque tested with various temperature gradients across the bearing. **Result:** Preload was lost when temperature gradient exceeded 5K. This result agreed with analytical prediction. Preload is lost because outer race is temporarily too large to maintain contact with the balls.

Bearing Test 2: Objective: To measure the bearing initial torque at 35K, having periodically rotated the bearing from 150K down to the operating temperature. The purpose of the test was to see if a mitigating strategy could be implemented during the cooling down of the bearing. **Result:** The rotating of the bearing during the cool down (temperature gradient > 5K) did not eliminate the high initial torque when rotated at 35K. Rotating the bearing with no preload on the ball / race system was in-effective.

Bearing Test 3: Objective: To measure the bearing initial torque at 35K, having maintained the temperature gradient across the inner and outer races at less than 5K. In essence, the bearing would be cooled in an iso-thermal manner. Providing an iso-thermal cool down of the bearing could be achieved, the preload between the balls and the races would be maintained during the entire cool down from 295K to 35K. **Result:** The temperature gradient across the bearing was maintained during the entire cool down at 4K or less. Therefore, it was assumed that the preload had been maintained on the bearing. However, a high initial torque of 80 N-cm occurred, but it was observed that the torque reduced down to 10 N-cm in only 10 degrees of bearing rotation. This rapid drop in torque had not been observed on any previous bearing test. It was concluded that the iso-thermal cool down had resulted in better bearing behavior at 35K, but the retainer itself could not be eliminated as a possible contributor to the high initial torque.

In parallel with the individual bearing tests the flight wheel / hub assembly (bearings having the enlarged retainer) was torque tested at 35K. The results of the pupil wheel bearing test was an initial torque of 167 N-cm. Dropping to 31 N-cm after 270 degrees of bearing rotation. The torque trace of the next three and a half revolutions is shown in Figure 10. The torque value drops from 27 N-cm to 13 N-cm in non-linear manner with respect to the rotation angle. Over the next 50 revolutions the torque reduced to an acceptable low value of only 7 N-cm.

The wheel / hub assembly still showed a high initial torque at 35K, despite the use of the larger diameter retainer. A review of the temperature data during the cool down revealed that the bearing had experienced a very high temperature gradient across the races (at one point the wheel being 100K warmer than the hub). This large temperature gradient led to a loss of bearing preload and when the

preload is lost the balls and the retainer could “fall” in the presence of 1G loads into non-optimal locations. These non-optimal locations would be “locked in” when the balls and races re-register, when all bearing components reach 35K. It is theorized that over the first four revolutions the balls are being put back into optimal locations by the act of rotating the bearing.

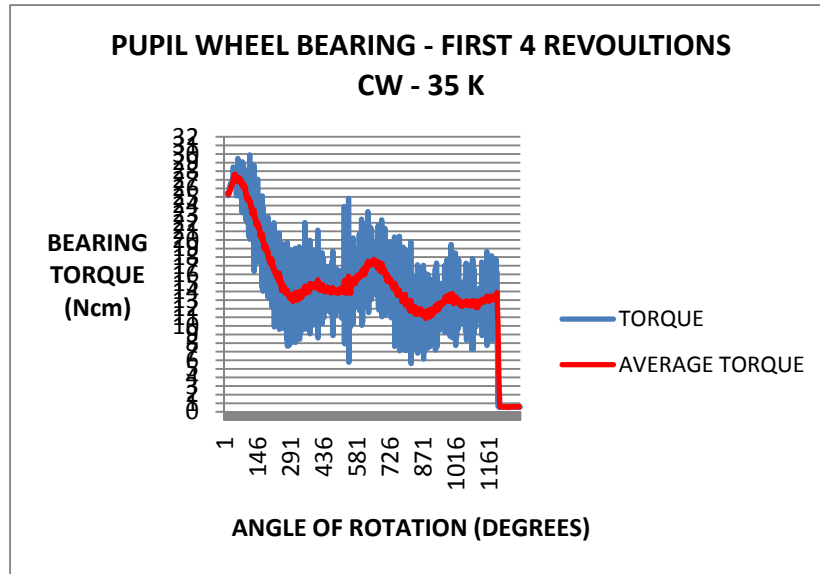

Figure 10. Wheel / Hub Assembly Torque Test at 35 K

The test also proved that the bearing high initial torque could not be due to frozen moisture in the MoS₂. The reason for this conclusion is that a high torque (if due to this phenomena) should clear itself in a single rotation of each ball relative to the races. But the bearing took four rotations to recover. It was not considered plausible that frozen moisture in the MoS₂ could affect the bearing for this many rotations.

Dual Wheel Mechanism Flight Model Tests

It was decided to proceed with the assembly of the DW flight model. Initially, both wheels were tested at room temperature, to establish a clear baseline for performance before testing at 35K. The minimum current for successful operation of each wheel was established at room temperature and then a torque ratio was calculated, based on the maximum motor drive current available. The torque ratios at room temperature were 4.4 for the PW and 4.1 for the FW. After vibration tests were completed, the torque ratios were unchanged. Vibration tests were deemed to be successful.

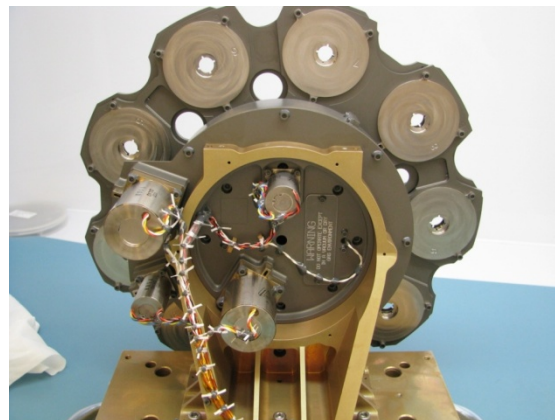

Figure 11. Dual Wheel Mechanism Flight Model

The first cryogenic temperature test at 35K was completed and the results were satisfactory in terms of overcoming the high torque of the bearings when initially turned at 35K. The torque ratio available to initiate rotation of the wheels (some missed steps permitted), at 35K, was 5.0 for the PW and 3.0 for the FW. The torque ratio is defined as the maximum motor current available divided by the minimum motor current required to simply achieve wheel rotation.

After a run in of the bearings (25 revolutions of each bearing) the torque ratio at the start of science operations (no missed motor steps permitted) at the beginning of life of the mechanism was 2.75 for the PW and 1.83 for the FW. The difference in the torque ratio values was attributed to the fact that the PW geared motor demonstrated a higher pull in torque (31 N-cm) at 35K than the FW geared motor (22 N-cm).

The temperature gradient measured across the bearings (during the cool down) was only 30K. A much lower value than that measured during the cool down of "bearing only" tests. This was attributed to the larger thermal inertia of the all up DW mechanism assembly. It was learnt that each different configuration of hardware cooled to 35K produced very different thermal gradients within the assembly.

The repeatability of positioning each optical element was demonstrated at 35K. The repeatability of the FW was ± 0.133 mm and the PW was ± 0.183 mm, versus a requirement for each wheel of ± 0.2 mm.

Conclusions and Lessons Learned

Item (1) – The bearing retainer suffered an interference condition with the inner race at the cryogenic temperature. This was attributed to an inappropriate CTE design value for the PGM-HT material. The interference was eliminated by enlarging the inside diameter of the retainer. Visual evidence of adequate clearance was obtained by adding a window to the bearing test fixture. It is recommended that precise knowledge of the CTE value of non-metallic retainers be used for designs intended for cryogenic applications.

Item (2) - A non-metallic bearing retainer may be in a non-optimal location when a bearing is initially rotated at cryogenic temperature. This causes a higher than normal torque. This may be caused by the relatively large dimensional change of the retainer cooling down to the cryogenic temperature. The retainer being under a 1G load and being offset from an ideal location may magnify this problem. This problem was rectified by a 10 degree rotation of the bearing provided the bearing was cooled in an isothermal manner. A metallic retainer may eliminate this problem.

Item (3) – When a bearing is cooled in such a way that a large thermal gradient occurs across the bearing, the bearing preload is lost. The loss of preload allows the ball and race system to be in a non-optimal location during the bearing cool down. Also, it is possible that the 1G load pulls the balls and the retainer off center. The balls re-register with the races in a non-optimal location when the preload is re-applied at the cryogenic temperature. The non-optimal location of the balls causes a higher than normal torque when initially rotated at cryogenic temperature. This problem can be rectified by up to four rotations of the bearing. It is recommended that mechanisms be cooled in an isothermal manner. The requirement to cool isothermally is problematic if accelerated cool downs are required for supporting ground tests.

Item (4) – The mechanism level tests cool the DW mechanism in six days. This invites item (3) to occur. Item (2) will always occur even if the mechanism is cooled isothermally over a long period of time.

Item (5) – Bearings behave in a normal manner after items (2) and (3) have been overcome. Tests confirmed that a mechanism torque ratio of greater than 3.0 was available to overcome the problem from items (2) and (3).

Item (6) – The JWST mission cool down is over a several week period. COM DEV expect item (2) to occur in the mission, but not item (3) to occur. However, it was decided to use the accelerated six day cool down as the basis for qualification. Future ground based testing at the instrument level will also have to cool down in six days. This is more severe than the mission itself but now serves as the environment for qualification.

The bearing anomalies described could not be eliminated from the design. However, a successful test campaign of the flight model ultimately lead to establishing acceptable torque ratios to overcome the anomalies.

The authors wish to express their gratitude to COM DEV and Canadian Space Agency management and to COM DEV technical and test personnel for their considerable support in tackling the complex design, build and test campaign for the DW mechanism.

References

1. National Institute for Standards and Technology, 325 Broadway, Boulder, Colorado